

# Product Overview | 4055 Igniters

## 4055 IGNITERS WITH FIXED LENGTH

Using direct spark ignition to light gas burners has many advantages over premix pilots. Direct spark igniters are generally less expensive, are easier to install and require less maintenance. They are also more convenient to use than manual torch lighting and they do not require personnel to be close to the burner exit while lighting.

Always consult the burner product documentation when picking an ignition system. Most industrial oil burners, and some gas burners cannot be lit reliably with direct spark ignition. In some cases, the extra air from a premix pilot system provides other benefits.

North American gas burners listed below can be lit directly with 4055 fixed length igniters.

### Fire•All™

4422, 4423, 4424, 4425

### Flat Flame™

4828, 4831, 4832, 4833, 4836, 4837

### HiRam®

4575

### Tempest®

4442 (alternative to standard 10mm spark plug)

Standard 6000 volt transformers (4065/4066) and ignition cables (4085) are used with these igniters.

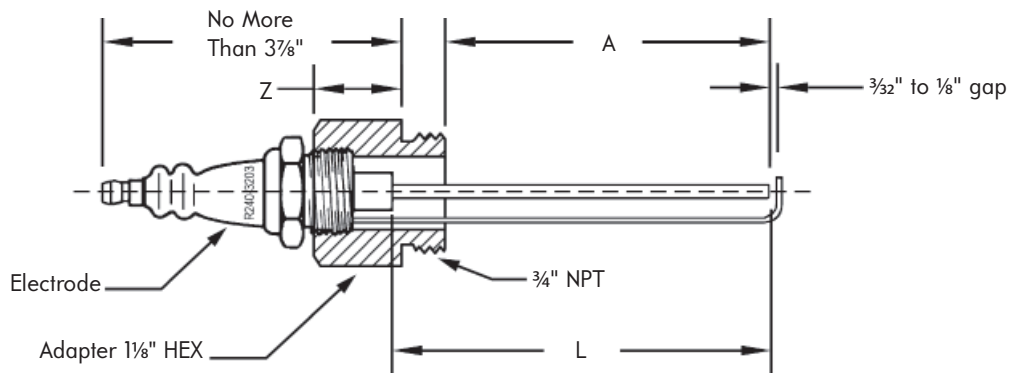

## 4055-A-B-C-D-E DIMENSIONS and SPARE PARTS

Designation	"A" Dimension	"L" Dimension	"Z" Dimension	Electrode*	Adapter
4055-A	1"	1 7/32"	1 3/16"	4-7865-2	OA4-1790-1
4055-B	2 3/8"	3 3/32"	1 11/32"	4-7865-1	OA4-1790-2
4055-C	2 7/8"	3 3/32"	1 3/16"	4-7865-1	OA4-1790-1
4055-D	1 11/16"	1 29/32"	1 3/16"	4-7865-3	OA4-1790-1
4055-E	1 7/8"	2 3/32"	1 3/16"	4-7865-4	OA4-1790-1

## 4055-A-B-C-D-E APPLICATION SIZING GUIDE

Burner designation	Igniter designation	Burner designation	Igniter designation
4422-2 thru -6-B	4055-D	4828-5 thru -8	4055-B
4422-7 and -8	4055-B	4831-0 and -1	4055-A
4423-0, 4424-0	4055-D	4832-2 thru -4	4055-C
4423-1 thru -3	4055-C	4832-5 thru -7	4055-B
4424-1 thru -3	4055-C	4833-3 and -4	4055-C
4425-2 thru -6-B	4055-D	4833-5 thru -8-A	4055-B
4425-7 and -8	4055-B	4836-2 thru -4	4055-C
4442-0 thru -4	4055-A	4836-5 thru -8	4055-B
4442-5 and -7	4055-D	4837-3 and -4	4055-C
4575-8 thru -14	4055-E	4837-5 thru -8-A	4055-B