

## ORDERING INFORMATION

- Determine the size of injector required, 2½" or 3½" based on natural gas (0.6 sg.) fuel flow.

|           | (units) | 2½"         | 3½"           |
|-----------|---------|-------------|---------------|
| Fuel Flow | scfh    | 2000 - 8500 | 8500 - 30,000 |

- Determine appropriate injector clock position location with respect to the burner centerline and choose injector part number.

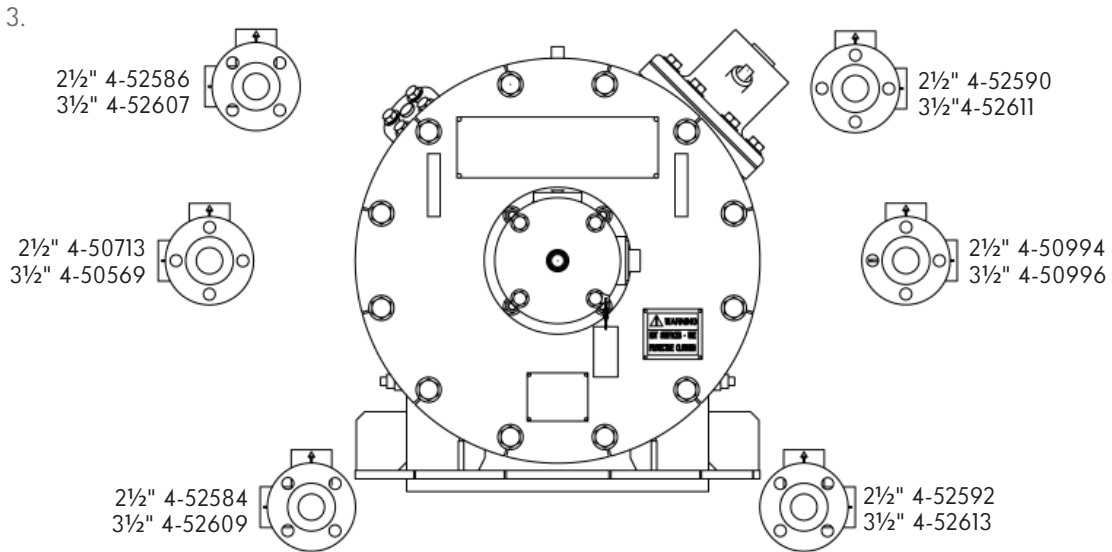

| Clock Position | 2½" Injector Part Number | 3½" Injector Part Number |
|----------------|--------------------------|--------------------------|
| 1:30-2:30      | 4-52590                  | 4-52611                  |
| 3:00           | 4-50994                  | 4-50996                  |
| 3:30-4:30      | 4-52592                  | 4-52613                  |
| 7:30-8:30      | 4-52584                  | 4-52609                  |
| 9:00           | 4-50713                  | 4-50569                  |
| 9:30-10:30     | 4-52586                  | 4-52607                  |