

# Dimensions | Light Oil Pump

## 8563- -A PUMP SET SPECIFICATIONS

**8563- -A Pump Sets** consist of an 8564 Pump with appropriate accessory equipment pre-piped for convenience.

Circled item numbers apply to drawing below.

Pump Set	Oil Pump <sup>①</sup> with TEFC motor	Diaphragm Relief Valve <sup>③</sup>	Basket Type Strainer <sup>②</sup>	Horizontal Swing Check Oil Valve <sup>④</sup>	Pressure Gauge <sup>⑥</sup> and ¼" Ball Valve (1821B-03) <sup>⑤</sup>
8563-1.5	8564-1.5	7177A-01-75 (or 150) (½")	8555B-1-CI-SST-20-S (1")	R920-1423 (1")	8735-160P-LF (0-160 psi)
8563-3.5	8564-3.5	7177A-01-75 (or 150) (½")	8555B-1-CI-SST-20-S (1")	R920-1423 (1")	8735-160P-LF (0-160 psi)

⑤ Bracket 11-14494-1

⑥ Bracket Strap 11-16130-1

⑦ Pump Information Decal

### DIMENSIONS inches

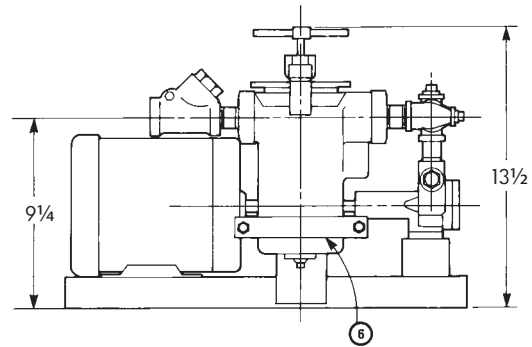
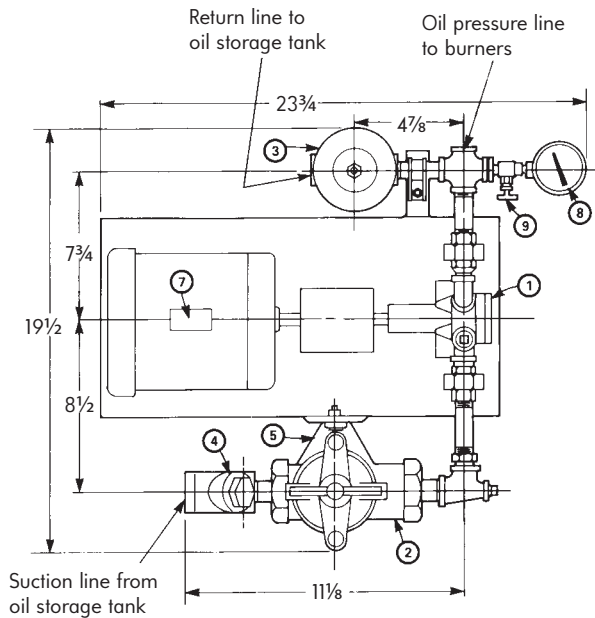

8563- -A Packaged Pump Set for Light Oil

To order, specify: 8563-1.5 (or 3.5) - (1 for single phase or 3 for three phase) / A modifier (75 for st'd spring [25 to 75 psig range] in relief valve, 150 for special spring at additional cost [70 to 150 psig]).

Example: 8563-3.5-3/A75 Oil Pump Set assembled (st'd spring in relief valve)

Pump will be supplied with TEFC motor. Electrical power to be as follows:

8563-1.5 (or 3.5)-1 Electric: 115/230/1/60

8563-1.5 (or 3.5)-3 Electric: 230/460/3/60

Consult North American for special power requirements.

DIMENSIONS SHOWN ARE SUBJECT TO CHANGE. PLEASE OBTAIN CERTIFIED PRINTS FROM FIVES NORTH AMERICAN COMBUSTION, INC. IF SPACE LIMITATIONS OR OTHER CONSIDERATIONS MAKE EXACT DIMENSION(S) CRITICAL.