

WATERBOX GASKETS

TABLE 20 - CONDENSER COMPACT WATERBOXES 150 PSI

SHELL CODE	1 PASS		2 PASS		3 PASS	
	GASKET P/N	FEET REQUIRED	GASKET P/N	FEET REQUIRED	GASKET P/N	FEET REQUIRED
2P, 2Q, 2R, 2S, 22, 23	028-16790	2'	028-16790	2'	028-16790	4'
4P, 4Q, 4R, 4S, 42, 43, 44, 45	028-16790	2.5'	028-16790	2.5'	028-16790	4.5'
6P, 6Q, 6R, 6S, 6T, 63, 64	028-16790	3'	028-16790	3'	028-16790	5'

NOTE: When ordering Gasket Material specify length required by replacing the -000 with either -025 for 25', -050 for 50', or -100 for 100'.

TABLE 21 - CONDENSER MARINE WATERBOXES 150 PSI

SHELL CODE	1 PASS		2 PASS		3 PASS	
	GASKET P/N	FEET REQUIRED	GASKET P/N	FEET REQUIRED	GASKET P/N	FEET REQUIRED
2P, 2Q, 2R, 2S, 22, 23	028-16790	23"	028-16790	15"	028-16790	30"
4P, 4Q, 4R, 4S, 42, 43, 44, 45	028-16790	27.5"	028-16790	18"	028-16790	35.5"
6P, 6Q, 6R, 6S, 6T, 63, 64	028-16790	31.5"	028-16790	20.5"	028-16790	41"

NOTE: When ordering Gasket Material specify length required by replacing the -000 with either -025 for 25', -050 for 50', or -100 for 100'.

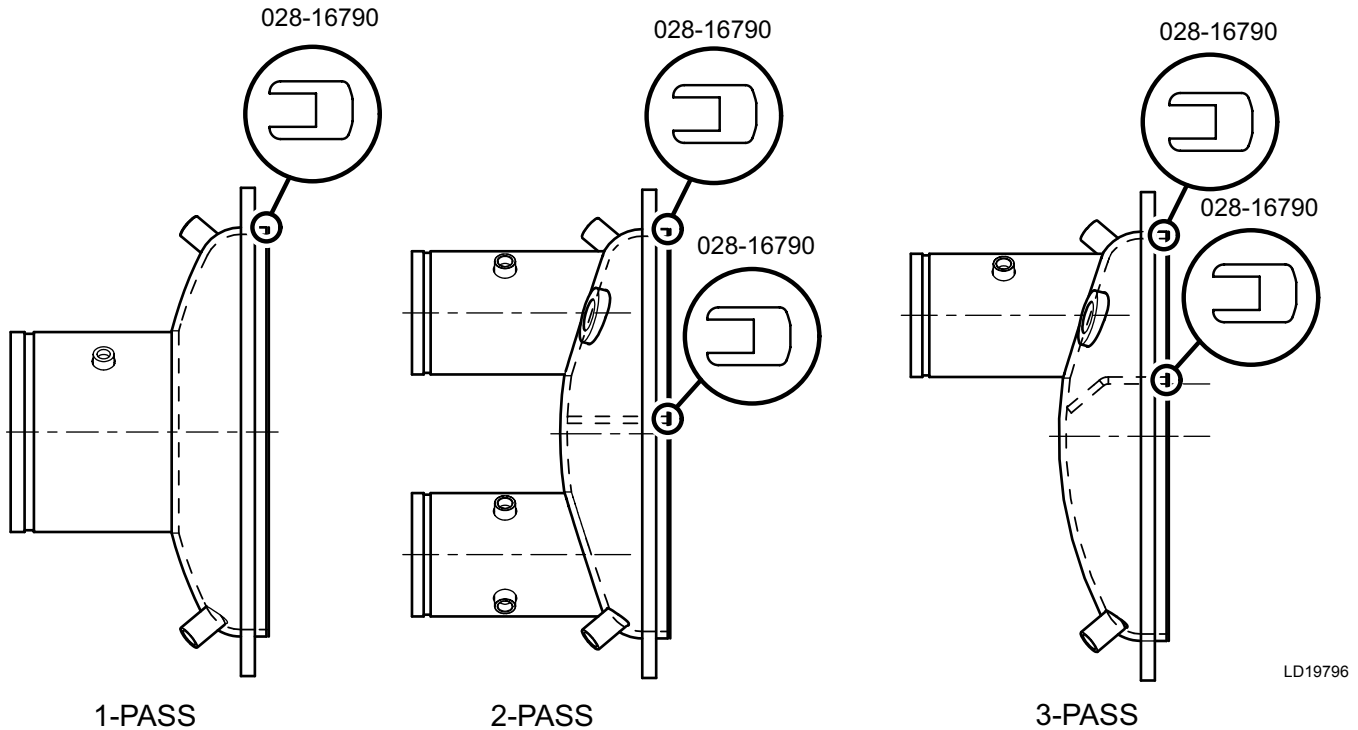

LD19796

FIGURE 36 - CONDENSER 150 LB. WATERBOX GASKET