

SECTION 2 - FAN COMPONENTS

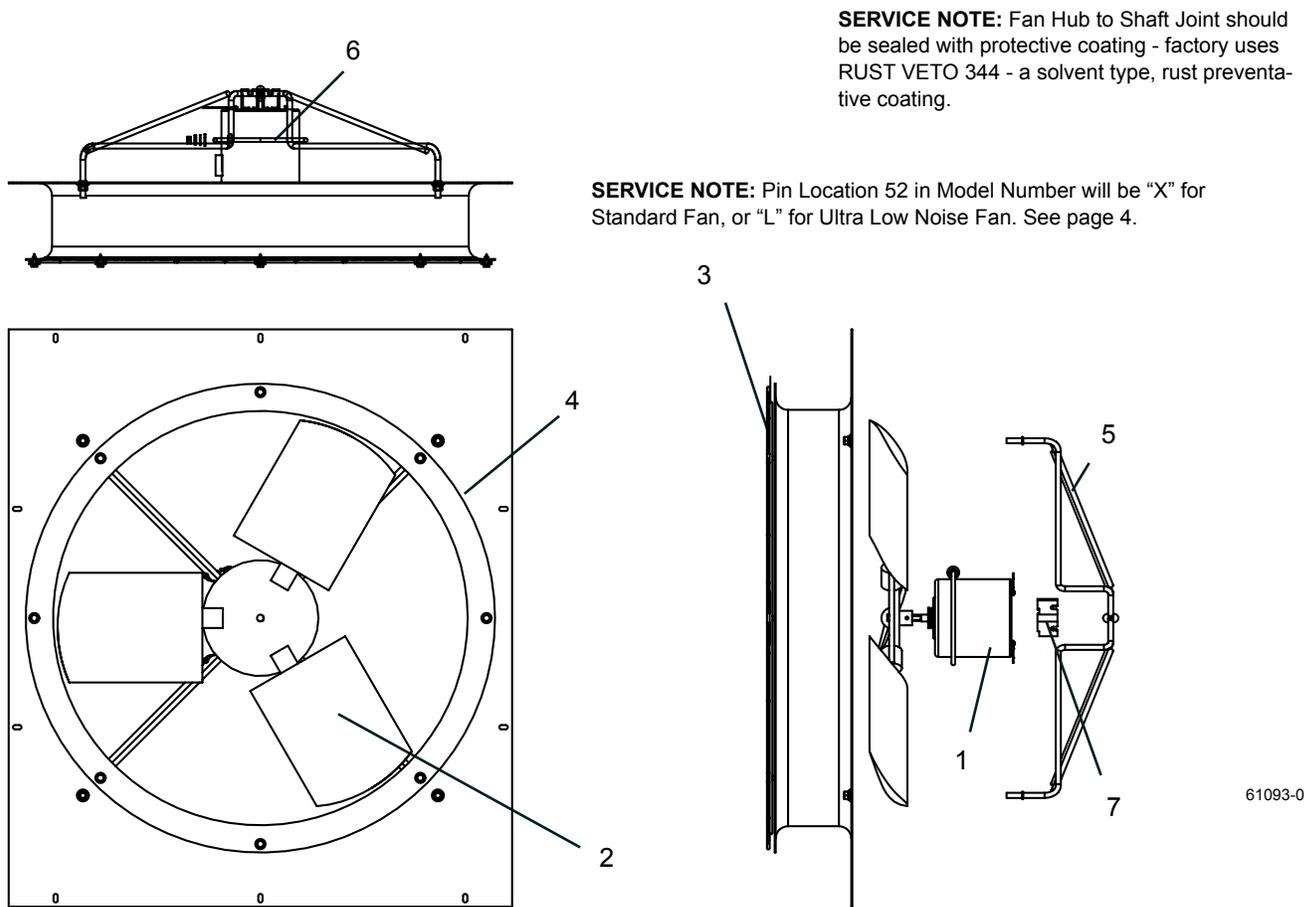

61093-0

FIGURE 3 - FAN COMPONENTS - MODELS QCC2015C AND QCC2020C

TABLE 3 - FAN COMPONENTS - MODELS QCC2015C AND QCC2020C

ITEM	DESCRIPTION	VOLTAGE CODE	FAN TYPE	
			STANDARD 7/8", 1075 RPM	ULTRA LOW NOISE 7/8", 850 RPM
1 ^s	Motor, Fan .5 HP (QCC2015C & QCC2020C)	-17	024-35427-002	n/a
		-28	024-35427-002	
		-40	024-35427-004	
		-46	024-35427-001	
		-50	024-35427-001	
		-58	024-35427-003	
2 ^s	Blade	All	026-43008-000	n/a
3	Guard	All	026-37521-000	
4	Orifice	All	026-43010-000	
5	Support, Fan	All	026-43007-000	n/a
6	Support, Ring	All	026-38369-000	
7	Hub, Square	All		

^s = Recommended Spare Parts